

MODEL REC102 110 GALLON CAPACITY ANIMAL RESISTANT TRASH/RECYCLE RECEPTACLE

- Uses two standard 55 gallon recycle type bags.
- ADA compliant.
- Easy access top loading chutes.
- Pivoting bag racks for easy trash removal.

Mechanical specifications

- Door hinges are heavy duty stainless steel for superior corrosion resistance and longevity.
 - Animal resistant internal single point self latching system on service hatch.
 - Welded 14 gauge construction.
 - 3/16" thick mounts with (4) holes bored to fit 1/2" bolts.
 - Powder coated for superior corrosion protection.
- Available in forest green, blue, brown, and gray.

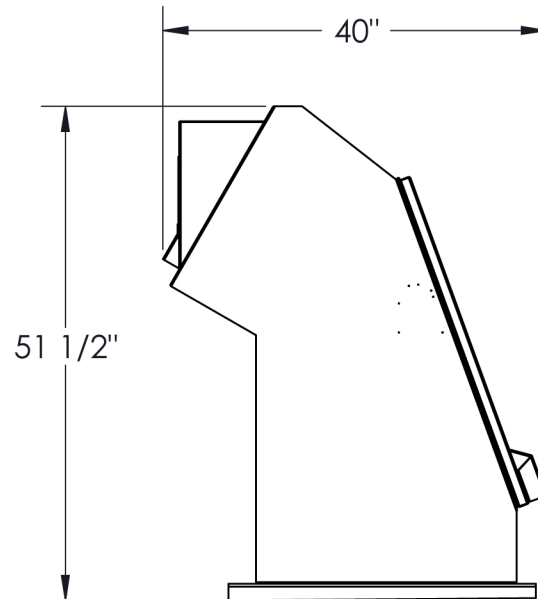
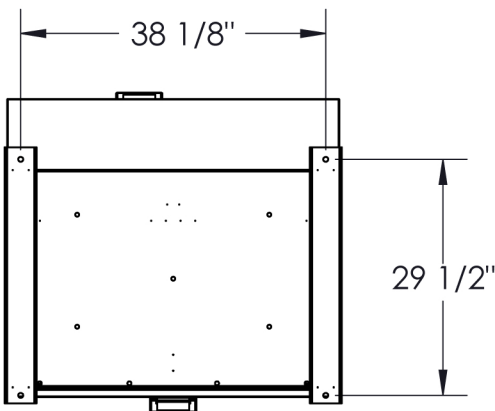
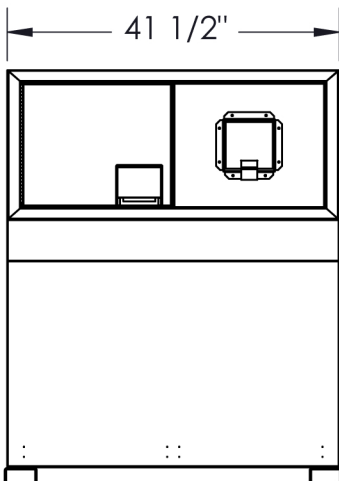

ESTIMATED WEIGHT: 285 LBS