



*Model LOC301 15 cu. ft. Bear Resistant Food Locker  
with black textured powder coated finish.*

- **Certified by the Interagency Grizzly Bear Committee**
- **15 cubic foot capacity protects food and property from bears**
- **12 ga. steel plate construction**
- **12 ga. pregalvanized steel plate bottom panel**
- **Reinforced door has full length continuous hinge and reinforced latch**
- **Meets ADA guidelines for accessibility**
- **Latch can be operated from inside for safety**
- **Air louvers in back panel allow ventilation but restrict insect access**
- **Top interior support channel includes hooks for hanging bags**
- **Leveling feet with included concrete anchors adjust for uneven mounting surface**
- **Units can be stacked to maximize storage capacity in small spaces**
- **Textured powder coat finish**

**SPECIFICATIONS:**

- **Ranger Series Bear Resistant Food Locker** provides secure storage of food and property in camping areas where bears frequently raid campsites for food. The locker has been tested and certified by the Interagency Grizzly Bear Committee as being bear resistant. The locker also meets ADA accessibility guidelines.
- **Model LOC301**  
40-3/8"h x 26"w x 34-1/2"d.
- Nominal outside locker box dimensions are 33"h x 26"w x 34-1/2"d, creating a 15 cu. ft. inside capacity.
- The food locker box is constructed of die-formed 12 ga. steel plate side, back, and top panels welded to die-formed 12 ga. steel channels that form a reinforcing framework.
- The door is die-formed 12 ga. steel plate with steel angle reinforcement, mounted on a steel continuous hinge. The reinforced steel latch secures the door at the top and bottom. An outside cover over the latch allows human operation while preventing access by bears. As a safety feature, the latch can be operated from inside the locker.
- The back panel of the locker includes louvered ventilation openings that restrict insect access.
- The size of the locker allows most coolers to be opened while inside the locker. An interior top support channel includes cutouts designed as hooks for hanging bags.
- The bottom panel of the locker is constructed of die-formed pregalvanized 12 ga. steel.
- Four adjustable mounting plates with four 1/2" x 5" concrete screw anchors (Anchor Kit #ANC5-4) are included to allow leveling and securing on uneven surfaces. The food locker must be anchored to a concrete surface to be bear resistant.
- Bolt hole knock-outs are provided in the top panel to allow like-sized units to be stacked and secured to maximize storage in minimal spaces.
- Unit ships fully assembled, ready for installation.

**AVAILABLE OPTIONS**

Textured powder coat finish available in four colors

**Bearicuda Bins**

Bearicuda Bins | PO Box 56, 3 West Street, Suite 3E | Litchfield, CT 06759-0056 | 877-BEARICUDA (232-7428)

[www.bearicuda.com](http://www.bearicuda.com)

Bearicuda is a registered trademark of Bearicuda Bins | © 2012, Bearicuda Bins All rights reserved.

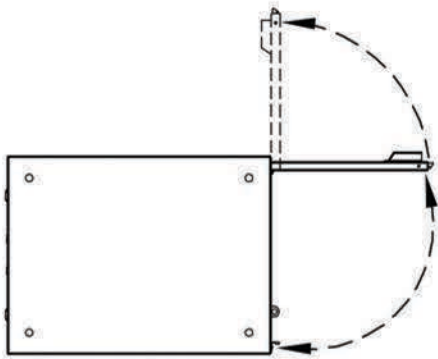

TOP VIEW

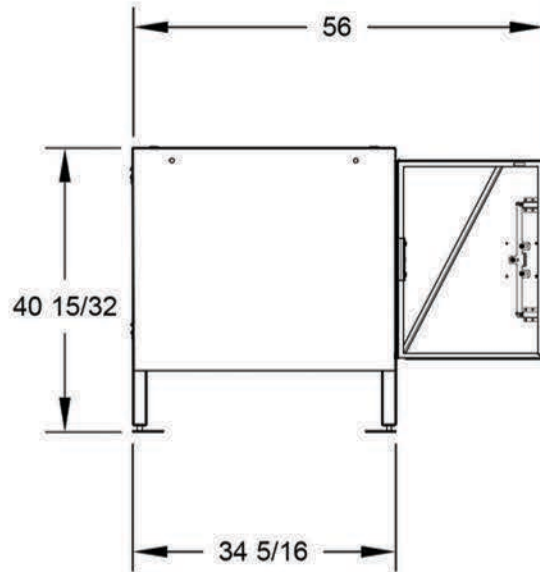

SIDE VIEW

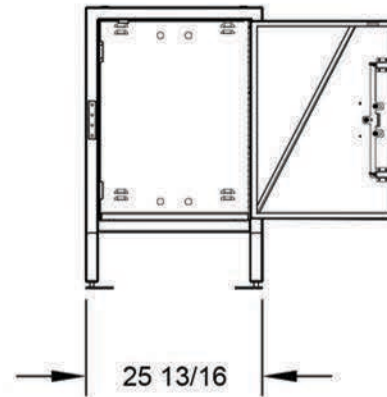

FRONT VIEW

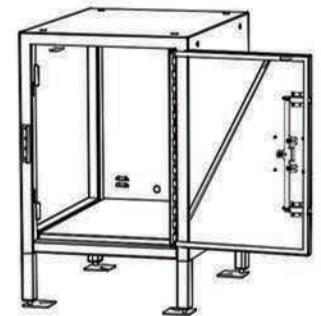
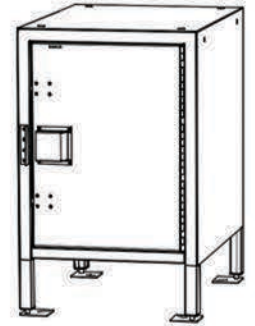

ALL DIMENSIONS IN INCHES

**Bearicuda Bins**  
 PO Box 56, 3 West Street, Suite 3E  
 Litchfield, CT 06759-0056

DRAWN BY  
**MFI**

TITLE MODEL LOC301 15 CUBIC FT. BEAR RESISTANT FOOD LOCKER

DATE 2-11-16

DWG. NO. AI-2064